

TESA VERIBOR Light Bore Gauge

Two-point contact gauge made to measure bores and form errors –
Self-centring – Can equally be used with a dial gauge, precision indicator
or any other sensor type having a 8 h6 dia. clamping shaft.



Measuring bolts and anvils in steel, hardened to 60 HRC ± 2 and 63 HRC ± 3 , respectively.



Mount for a sensor having a 8h6 dia. clamping shaft



2 μm



4 μm



Set including 1 single TESA VERIBOR Light plus 1 set of interchangeable fixed inserts covering the whole application range.



Wooden case



Declaration of conformity

Nº

=



mm



Bolt travel, mm



Measuring depth, mm

05710090	TESA Veribor Light	18 ÷ 35	1,30	176
05710091	TESA Veribor Light	35 ÷ 60	1,40	178
05710092	TESA Veribor Light	50 ÷ 150	1,40	178
05710093	TESA Veribor Light	18 ÷ 150	1,30 / 1,40	176 / 178

Dial gauge not included.

TESA VERIBOR with dial gauge

No	No	No	No	mm
05710054	05710061			4,5 ÷ 6
05710055	05710062			6 ÷ 12,5
05710056	05710063			12 ÷ 25
		05710057	05710064	25 ÷ 50
		05710058	05710065	50 ÷ 150
		05710059	05710066	50 ÷ 300
		05710060	05710067	240 ÷ 550

Provided with a TESA dial gauge

No	01412010	01412510	01412310	01412511
mm	40	40	58	58
mm	0,01	0,001	0,01	0,001



Full set including 1 single TESA VERIBOR Light plus 1 set of interchangeable fixed inserts covering the whole application range, 1 dial gauge as shown in the table opposite, 1 dial gauge guard.



Wooden case



Declaration of conformity

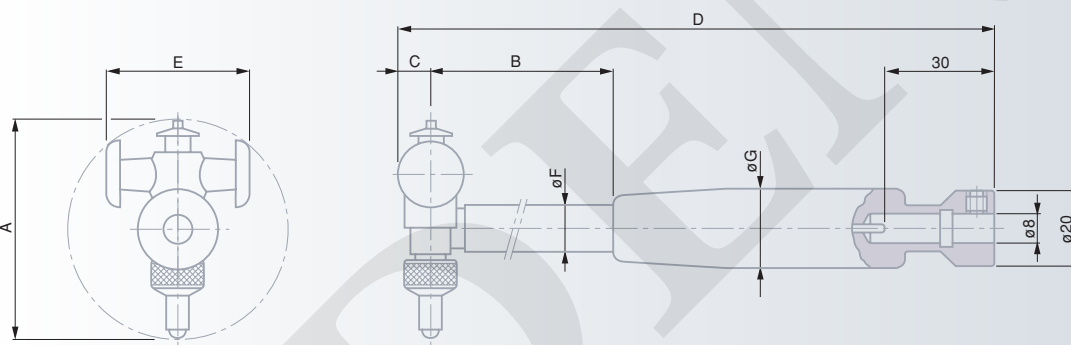

A mm	mm	B mm	C mm	D mm	E mm	F mm	G mm
4,5 ÷ 6	0,35	74	2	138	3,3	3,8	16
6 ÷ 12,5	0,5	93	2,6	156	4,3	4,9	16
12 ÷ 25	0,9	106	4,5	194	7,8	7,9	19
25 ÷ 50	1,3	140	6	228	16	8	19
50 ÷ 150	1,4	173	10	279	36	12	23
50 ÷ 300	1,4	173	10	279	36/66	12	23
240 ÷ 550	1,6	227	14	347	112	18	28

Special Versions

Available on request:

- TESA VERIBOR for blind bores and centring shoulders.
- TESA VERIBOR elbow-shaped for hard-to-reach bores.
- Handtools for measuring the distance between two plan-parallel surfaces.
- Handtools for inspecting gear pitch diameters.



Optional Accessories for TESA VERIBOR Bore Gauges

Set of extensions

For extending the application range of VERIBOR No. 05710016, 05710058 and 05710065 up to 300 mm dia.



mm

05740001

Consisting of:

- 1 Centring shoe
- 3 Extensions 50 mm



Depth extensions (not pictured)

To be mounted on each tool shaft from diameters ≥ 25 to ≤ 550 mm for depth increase (Size B – Drawing on page H-12).



mm

- 05760026** 250
- 05760027** 500
- 05760028** 750
- 05760029** 1000

Dial gauge guard

Protects the dial gauge against shocks. Also prevents the dial from being inadvertently rotated.



mm

- 05760012** $\varnothing 40$
- 05760013** $\varnothing 58$



Cable holder

Used for the probe cable. To be mounted at the end of the gauge shaft.



05760014

